



 NEVER COMPROMISE ON QUALITY AND SAFETY

**CAR LIFT CATALOG**

 **Schneider**<sup>TM</sup>  
Lift & Escalator  
Since 1992  
[www.asia-schneider.com](http://www.asia-schneider.com) 02 948 1663



\*Actual Product might differ from pictures.

## STANDARD CABIN FOR CAR LIFT

**CAR CEILING**  
ASC-A-02 Laminated Painted Steel  
with LED downlight

**CAR WALL**  
Painted Steel

**CAR DOOR**  
Painted Steel

**LANDING DOOR**  
Painted Steel

**COP & HOP**  
304 Hairline Stainless Steel with Dot-Matrix LED Screen  
and ASB-M-01 push button

**CAR FLOOR**  
Checkeded Plate

## CAR CEILINGS



ASC-A-01



ASC-A-02

\*Actual Product might differ from pictures.

### ASC-A-01

Laminated Painted Steel  
with LED Lighting and ventilation system

### ASC-A-02

Integrated Painted Steel  
with LED Down Lights and ventilation system

# DISPLAY TYPES

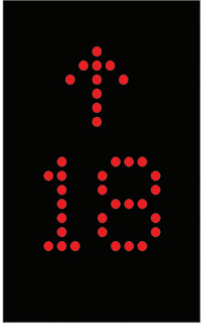

DOT-MATRIX



BLUE-SEGMENT  
LCD (OPTIONAL)

# PUSH BUTTONS



ASB-M-01



ASB-M-02



ASB-M-03



ASB-M-04



ASB-M-05



STANDARD



OPTIONAL

\*Actual Product might differ from pictures.

**AS-A-HOP 01**  
Hairline Stainless Steel with  
Dot-Matrix LCD Display

**AS-A-HOP 02**  
Hairline Stainless Steel with  
Blue-Segment LCD Display

**ASB-M-01**  
Round Hairline Stainless Steel  
with Braille button.

**ASB-M-03**  
Round Hairline Stainless Steel  
with Braille button.

**AS-A-COP 01**  
Hairline Stainless Steel with  
Dot-Matrix LCD Display

**AS-A-COP 02**  
Hairline Stainless Steel with  
Blue-Segment LCD Display

**ASB-M-02**  
Round Hairline Stainless Steel  
with Goldish background color

**ASB-M-04**  
Square Hairline Stainless Steel.

**ASB-M-05**  
Square Hairline Stainless Steel  
with Braille button.

# CAR FLOORS

ASF-A-01



ASF-A-02

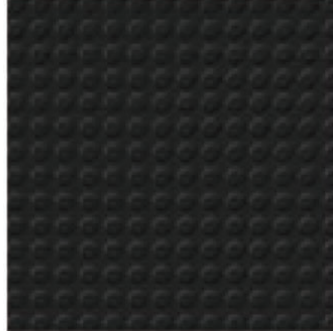

ASF-A-03



# CAR WALL



PS01



PS02



PS03



PS04

\*Actual Product might differ from pictures.

PS01 Gray	PS03 Green	ASF-A-01 Painted Steel Checkered Plate	ASF-A-03 Stainless Steel Checkered Plate
PS02 Cream	PS04 Space Gray	ASF-A-02 Black Rubber Plate	

Lift Shaft-SECTION VIEW

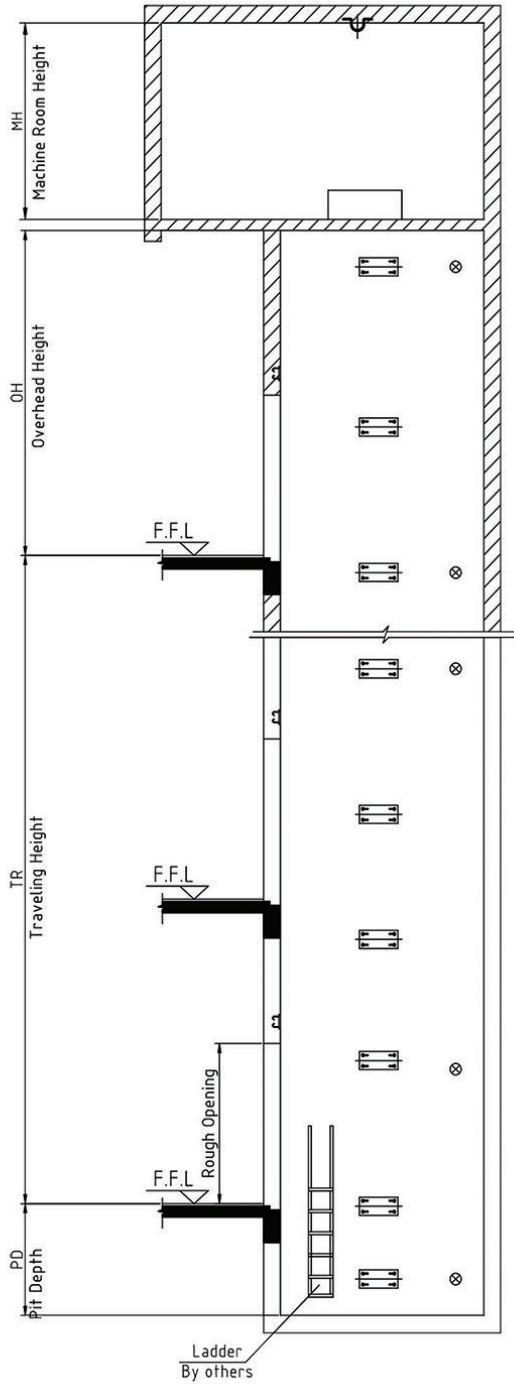

MACHINE ROOM PLAN

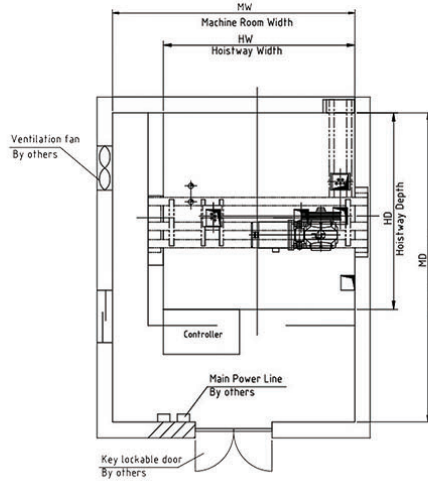

HOISTWAY PLAN

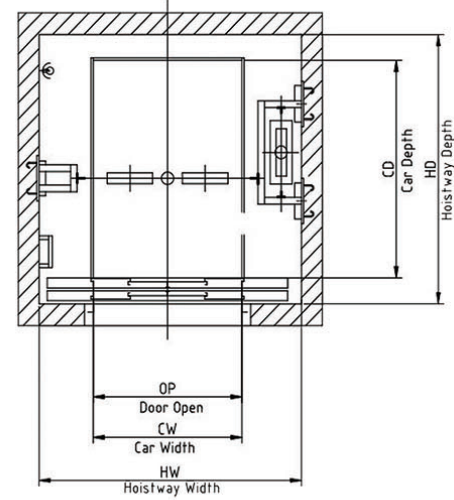

PLANNING GUIDE FOR DIMENSIONS (Overhead and Pit)

Capacity Load(kg)	OH (mm)	PIT (mm)	Car Clear Height (CIH) (mm)	Door Height (mm)
2000	4500(0.5m/s)	1400	2200 (without false ceiling)	2100
	4800(1.0m/s)			
3000/3500	4600	1600		
4000	4600	1600		
5000	5000	1600	2400 (without false ceiling)	2300

PLANNING GUIDE FOR DIMENSIONS (2000 - 4000kg)

Speed(m/s)	Max. Travel (m)	Capacity Load(kg)	Car Size	Door Opening(mm)	Std. Hoistway Size / HWxHD (mmxmm)	
			CWxCD(mmxmm)		Single Opening	Through Opening
0.5/1.0	40	2000	1700x2400	CO 1700, 4 pannels	3000x2950	3000x3000
0.5	40	3000	2000x2800	CO 2000, 4 pannels	3400x3350	3400x3400
		3500	2200x3000	CO 2200, 4 pannels	3800x3550	3800x3600
		4000	2000x3600	CO 2000, 4 pannels	3550x4150	3550x4200
		5000 *	2400x3600	CO 2400, 4 pannels	4050x4150	4050x4200

\* 5000kg is with 6 car guide rails.